

CPCD/CP(Q)YD 40/45/50

YC4G3 / KUG3(-06) / KU4G3-06

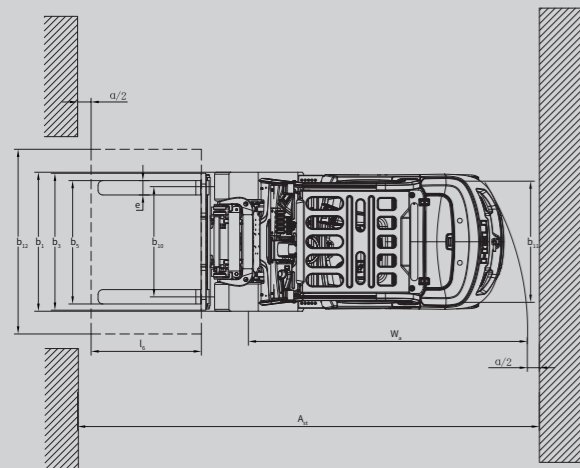

NOTE:

Vertical axle stands for load capacity while horizontal axle stands for load center. Load center is the distance counted from the front of the fork. The base point of the standard load is the center point of the cubic with the same 1200mm dimension in length, width and height. The load capacity should be down, if mask tilts forward, using non-standard forks or loading goods with extra width. Please notice the different load capacity between different load centers according to load chart.

- CPCD45
- CPCD50
- CPCD50@600
- CPCP40

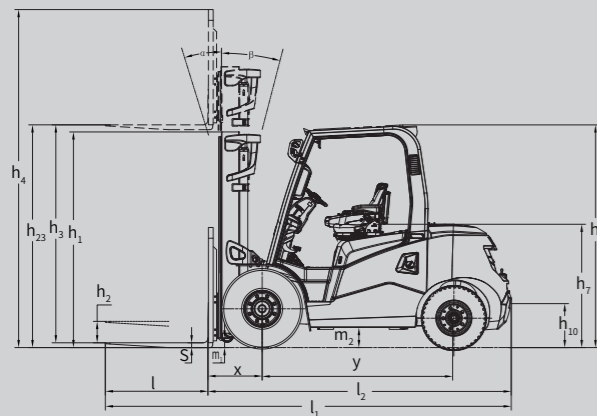
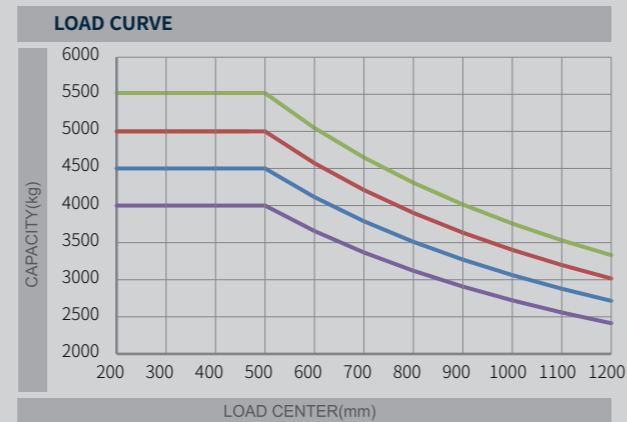

Standard configuration	Optional configuration	
Reversing handle (with horn)	Warning light	Fire extinguisher
Protection sleeve for steering cylinder	Cab	Fan
LED lights	Two stage free lift mast and three stage free lift mast	Reversing horn speaker
File folder	Dual tyre of front wheel and solid tyre	Coarse filter
HEAN semi enclosed seat	Thread	Over speed alarm
Middle wide angle rear view mirror	Synchronized steering system	Automatic weight system, overload alarm
Median exhaust	Rear view mirrors on both sides	Rear view system
Steering wheel with handle ball	Dual hose pulley block	Truck networking
Counter weight protection net	High exhaust	
Adjustable steering wheel	Double air filter	
Ratchet parking brake	Rear lamp	
Flexible connection casting steering axle	Protection sleeve for tilt cylinder	
Stamping overhead guard	GRAMMER'S full suspension seat	
Electric-hydraulic reversing control	Air conditioner	
Air filter with safety filter element	Heater	



AESTHETICS / FUNCTIONAL

A Design Of Perfect Combination



A NEW GENERATION OF PRODUCTS

Intelligent / Safe / Efficient / Saving and Environment Friendly

COMFORTABLE OPERATION

New family PI image design, appearance upgrade, optimized structure design and high-end configuration ensure comfortable operation from every detail.



Flexible connected intelligent shift hydraulic transmission has been verified by market for 30 years and has the features of mature and reliable, small vibration, convenient and comfortable operation;

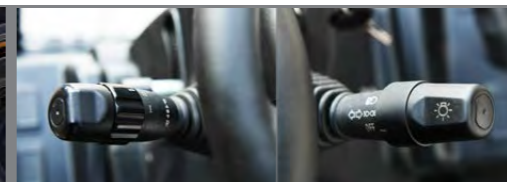

The standard configuration of electro-hydraulic reversing and steering handle and lamp combination handle improves the operation convenience;

- High quality damping system matched with professional calculation make the idle vibration isolation rate up to 68%; high quality Hutchinson damping pad is adopted and has the features of more stable damping effect and longer service life;



The tilt cylinder sinks to improve the leg space;



Full LCD color display CAN bus instrument fully monitors truck status; displays real-time engine and truck fault information and gives humanized reminder;



Wide view mast optimizes the blind area of operation vision and ensures comfortable and safe operation;



Standard configuration of mast lowering buffer makes it more comfortable to handle goods;



- The ratchet type parking brake handle is more labor-saving.
- Increased handle with leather anti-skid makes getting on and off more convenient; Reversing handle with horn makes truck reversing safer.

ENERGY SAVING AND ENVIRONMENT FRIENDLY

- Standard configuration of load sensing gives priority to steering and saves energy by 5%.
- The dual pump combined hydraulic system can supply flow on demand and reduce truck fuel consumption;
- Standard configuration of LED lights make truck more energy saving ,environment friendly,long life using and reliable.

HIGHER EFFICIENCY

- Enlarged high air intaking grid makes air intake smoother and engine power utilization more sufficient.
- Tail-free frame reduces truck center of gravity and improves truck lateral stability and bearing capacity at high.

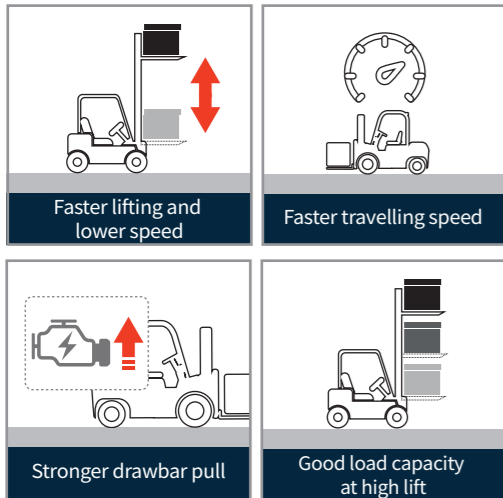

High strength integral welded overhead guard improves driving safety factor;

SAFE AND RELIABLE

- The standard hydraulic power assisted braking system has stronger tolerance to working environment (such as dust) and stable and reliable braking performance;
- The electro-hydraulic reversing box and control box are mature and reliable, and the pipeline layout is optimized to effectively reduce the failure rate of electrical components;
- The waterproof connector is safe and reliable;
- Increased pipe diameter of hydraulic system reduces the pressure loss and extends the service life of hydraulic components;
- Increase the aluminum plate fin radiator controls temperature in a good range and effectively improves the reliability of each system;
- The standard 8-inch air filter with safety filter element is equipped with air filter blockage alarm device to remind the maintenance of the air filter in time, protect the engine and improve the reliability of the engine;



- Equipped with cast steering axle, the strength of the axle body is increased by 30%, and the standard protective sleeve is provided;
- High strength integral welded overhead guard improves driving safety factor;
- The balance weight is optimized to improve the rear field of view and ensure the safety of operation;
- The rear wheels are equipped with Zhengxin 14-layer tires as standard to improve the service life of tires;
- The metal step is anti-skid, reliable and durable;
- The optimized brake can effectively prevent locking after rain, reduce braking impact, extend the service life of the brake, prevent excessive braking, and significantly improve the reliability and service life.

HELI smart fleet management system (optional)

Vehicle positioning	Vehicle management
Remote diagnosis	Identification recognition (optional)
Remote monitoring	Weight management (optional)
Maintenance reminder	Collision management (optional)
Statistical form	

EASY MAINTENANCE

- 80° opening angle, easy opening mechanism and optional key lock make repair and maintenance easy.
- Module design of electric system reduces maintenance cost.



CPCD/CP(Q)YD
40/45/50
DE2HG3/YC4G3/KUG3(-06)

Manufacturer and Technical Data							
Characteristics							
1.01	Manufacturer	TYMBIA					
1.02	Model	CPCD40/CP(Q)YD40-*	CPCD45/CP(Q)YD45-*	CPCD50/CP(Q)YD50-*	CPCD50/CP(Q)YD50-*06		
1.03	Rated capacity	Q	kg	4000	4500	4990	
1.04	Load center distance	c	mm	500			600
1.05	Power mode	Diesel/LPG/GAS					
1.06	Driving mode	Sit-on type					
1.07	Front overhang	x	mm	560			565
1.08	Rear overhang		mm	505	545	595	
1.09	Wheelbase	y	mm	2100			
Weight							
2.01	Total weight		kg	6250	6510	6920	
2.02	Axle load (laden,front/rear)		kg	9110/1140	9840/1170	10540/1370	
2.03	Axle load (unladen,front/rear)		kg	3100/3150	3080/3430	3030/3890	
Tyres							
3.01	Tyre type	Pneumatic type					
3.02	Tyre size,front	300-15-18PR (Double-tyre 8.25-15-14PR)					
3.03	Tyre size,rear	7.00-12-14PR					
3.04	Wheels,number front/rear (x=driven wheels)	2X/2(Double-tyre 4X/2)					
3.05	Tread, front	b ₁₀	mm	1210			
3.06	Tread, rear	b ₁₁	mm	1190			
Dimensions							
4.01	Mast tilt angle (forward/backward)	α/β	°	6/12			
4.02	Height (mast lowered)	h ₁	mm	2250			
4.03	Free lifting height	h ₂	mm	150			
4.04	Lifting height (standard)	h ₃	mm	3000			
4.05	Max. height,extended (with backrest)	h ₄	mm	4250	4405		
4.06	Height of overhead guard	h ₅	mm	2350			
4.07	Seat height relating to SIP (to ground)	h ₇	mm	1080			
4.08	Towing coupling height	h ₁₀	mm	430			
4.09	Overall length (with fork)	l ₁	mm	4255	4275	4325	
4.10	Overall length (without fork)	l ₁	mm	3165	3205	3255	
4.11	Overall width	b ₁	mm	1510			
4.12	Fork size:thickness x width x length	s/e/l	mm	50x150x1070	50x150x1070	50x150x1070	
4.13	Fork carriage,according to ISO2328			III	IV		
4.14	Distance across fork-arms, Max./Min.	b ₅	mm	1374/300			
4.15	Ground clearance (laden,between mast)	m ₁	mm	140			
4.16	Ground clearance (center of wheelbase)	m ₂	mm	230			
4.17	Right angle stacking aisle width for pallet 1000x1200mm crossways	Ast	mm	4610	4640	4690	
4.18	Right angle stacking aisle width for pallet 800x1200mm lengthways	Ast	mm	4810	4840	4890	
4.19	Min. outside turning radius	Wa	mm	2850	2880	2930	
Performance Data							
5.01	Travel speed (laden/unladen)		km/h	25/26			
5.02	Lift speed (laden/unladen)		m/s	0.58/0.62	0.53/0.58		
5.03	Lowering speed (laden/unladen)		m/s	0.45			
5.04	Max.drawbar pull (laden/unladen)		N	41/25			
5.05	Max.gradeability (laden/unladen)		%	38/28	36/28	33/28	
Combustion-engine							
6.01	Engine manufacturer/Moel			Deutz TCD 3.6 L04	YUCHAI YCF3675-S580	Kubota Certified WG3800 LPG	
6.02	Rated power/Speed		kW/rpm	55.4/2300	55.8/2200	59/2400	
6.03	Max. torque/Speed		Nm/rpm	406/1300	330/1300-1600	282/1200	
6.04	Cylinder number-bore x stroke			4-98mmx120mm	4-98mmx120mm	4-100mmx120mm	
6.05	Engine displacement		L	3.6	3.6	3.768	
6.06	Emission			Euro stage V/EPA T4F	Euro stage V	Euro stage V/EPA T4F	
6.07	Transmission gears (front/rear)			2/1-Power Shift			
6.08	Fuel tank capacity		L	110			
Addition data							
7.01	Service brake/Parking brake			Hydraulic assisted braking/Mechanical-ratchet type			
7.02	Operating pressure for attachments		Mpa	14			

Engine model and main specification technical data for option							
Engine model	Model	Power mode	Rated power/Speed (kW/rpm)	Max. torque/Speed (Nm/rpm)	Engine displacement (L)	Cylinder number-bore x stroke	Emission
YUCHAI YCF3675-S580	CPCD40/45/50-YC4G3, CPCD50-YC4G3-06	Diesel	55.8/2200	330/1300-1600	3.6	4-98mmx120mm	Euro stage V
Kubota Certified WG3800	CPYD/40/45/50-KUG3, CPYD50-KUG3-06	LPG	59/2400	282/1200	3.768	4-100mmx120mm	Euro stage V/EPA T4F
Kubota Certified WG3800	CPQYD/40/45/50-KUG3, CPQYD50-KUG3-06	LPG&GAS	50.6/2400	271(LPG)/1200 246(GAS)/1400	3.768	4-100mmx120mm	Euro stage V/EPA T4F
Kubota V3307-CR-T15	CPCD50-KU4G3-06, CPCD/40/45/50-KU4G3	Diesel	55.4/2200	335/1400	3.3	4-94mmx120mm	China IV/EurO stage V /EPA T4F

Wide View Standard Mast												
Mast model	Max.lifting height (mm)	Load capacity (lode center 500/600mm)(kg)				Height (mast lowered) (mm)	Free lift height (with backrest) (mm)	Service weight (kg)				Mast tilt angle α/β (°)
		4t@500	4.5t@500	5t@500	5t@600			4t@500	4.5t@500	5t@500	5t@600	
M250	2500	4000	4500	4990	5000	1990	150	6200	6460	6870	7230	6°/12°
M300	3000	4000	4500	4990	5000	2240	150	6250	6510	6920	7280	6°/12°
M330	3300	4000	4500	4990	5000	2390	150	6280	6540	6950	7310	6°/12°
M350	3500	4000	4500	4990	5000	2490	150	6300	6560	6970	7330	6°/12°
M370	3700	4000	4500	4990	5000	2590	150	6315	6575	6985	7345	6°/12°
M400	4000	4000	4500	4990	5000	2790	150	6390	6650	7060	7420	6°/12°
M425	4250	4000	4500	4990	5000	2915	150	6415	6675	7085	7445	6°/6°
M450	4500	*3800	*4300	*4700	*4700	3040	150	6435	6695	7105	7465	6°/6°
M475	4750	*3700	*4200	*4500	*4500	3165	150	6460	6720	7130	7490	6°/6°
M500	5000	*3700	*4200	*4500	*4500	3290	150	6485	6745	7155	7515	6°/6°
M550	5500	*3200	*3600	*4000	*3800	3590	150	6575	6835	7245	7605	6°/6°
M600	6000	*3200	*3600	*3800	*3500	3840	150	6625	6885	7295	7655	6°/6°

Note: * stands for the rated capacity when the front tyre is double-tyre.

Wide View Full Free 2-Stage Mast													
Mast model	Max.lifting height (mm)	Load capacity (lode center 500/600mm)(kg)				Height (mast lowered) (mm)	Free lift height (with backrest) (mm)		Service weight (kg)				Mast tilt angle α/β (°)
		4t@500	4.5t@500	5t@500	5t@600		4/4.5/5t@500	5t@600	4t@500	4.5t@500	5t@500	5t@600	
ZM250	2500	4000	4500	4990	5000	1990	785	640	6155	6415	6825	7290	6°/12°
ZM300	3000	4000	4500	4990	5000	2240	1035	890	6215	6475	6885	7350	6°/12°
ZM330	3300	4000	4500	4990	5000	2390	1185	1040	6255	6515	6925	7390	6°/12°
ZM350	3500	4000	4500	4990	5000	2490	1285	1140	6275	6535	6945	7415	6°/12°
ZM370	3700	4000	4500	4999	5000	2590	1385	1240	6300	6560	6970	7440	6°/12°
ZM400	4000	4000	4500	4990	5000	2790	1585	1440	6390	6650	7060	7535	6°/12°
ZM425	4250	4000	4500	4990	5000	2915	1710	1565	6430	6690	7100	7570	6°/6°
ZM450	4500	*3800	*4300	*4700	*4700	3040	1835	1690	6470	6730	7140	7615	6°/6°
ZM475	4750	*3700	*4200	*4500	*4500	3165	1960	1815	6510	6770	7180	7655	6°/6°
ZM500	5000	*3700	*4200	*4500	*4500	3290	2085	1940	6550	6810	7220	7695	6°/6°
ZM550	5500	*3200	*3600	*4000	*3800	3590	2385	2240	6660	6920	7330	7810	6°/6°
ZM600	6000	*3200	*3600	*3800	*3500	3840	2635	2490	6715	6975	7385	7865	6°/6°

Note: * stands for the rated capacity when the front tyre is double-tyre; free lift for 4t/4.5t/5t@500 (without backrest):+295mm; free lift for 5t@600 (without backrest):+447mm.

Wide View Full Free 3-Stage Mast														
Mast model	Max.lifting height (mm)	Load capacity (lode center 500/600mm)(kg)				Height (mast lowered) (mm)		Free lift height (with backrest) (mm)		Service weight (kg)				Mast tilt angle α/β (°)
		4t@500	4.5t@500	5t@500	5t@600	4/4.5/5t@500	5t@600	4/4.5/5t@500	5t@600	4t@500	4.5t@500	5t@500	5t@600	
ZSM360	3600	*3800	*4350	*4800	*4800	1940	1990	730	630	6365	6625	7035	7520	6°/6°
ZSM400	4000	*4000	*4500	*4990	*4990	2080	2130	870	770	6415	6675	7085	7590	6°/6°
ZSM435	4350	*3800	*4350	*4800	*4800	2190	2240	980	880	6455	6715	7125	7620	6°/6°
ZSM450	4500	*4000	*4500	*4990	*4990	2240	2290	1030	930	6475	6735	7145	7640	6°/6°
ZSM470	4700	*3800	*4300	*4700	*4700	2305	2355	1095	995	6495	6755	7165	7665	6°/6°
ZSM500	5000	*3250	*3800	*4200	*4000	2440	2490	1230	1130	6545	6805	7215	7720	6°/6°
ZSM540	5400	*3500	*4000	*4400	*4300	2590	2640	1380	1280	6655	6915	7325	7835	6°/6°
ZSM600	6000	*3200	*3400	*3800	*3500	2790	2840	1580	1480	6730	6990	7400	7910	6°/6°
ZSM650	6500	*2500	*2800	*3200	*3000	2990	3040	1780	1680	6800	7060	7470	7985	6°/6°
ZSM700	7000	*1800	*2000	*2500	*2300	3165	3215	1955	1855	6865	7125	7535	8060	6°/6°

Note: * stands for the rated capacity when the front tyre is double-tyre; free lift for 4t/4.5t/5t@500 (without backrest):+340mm; free lift for 5t@600 (without backrest):+430mm.